

REVISION HISTORY		
REV	DATE	ECN
-	03/11/21	21-0295

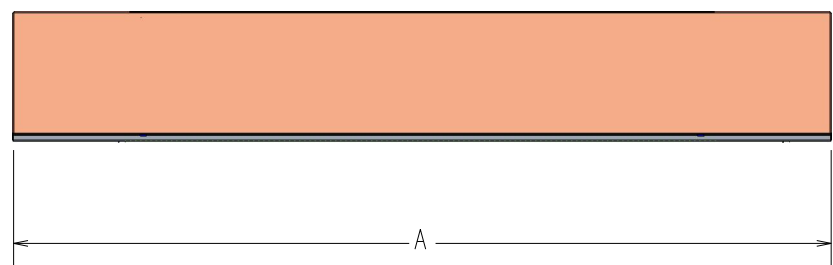

TOP VIEW

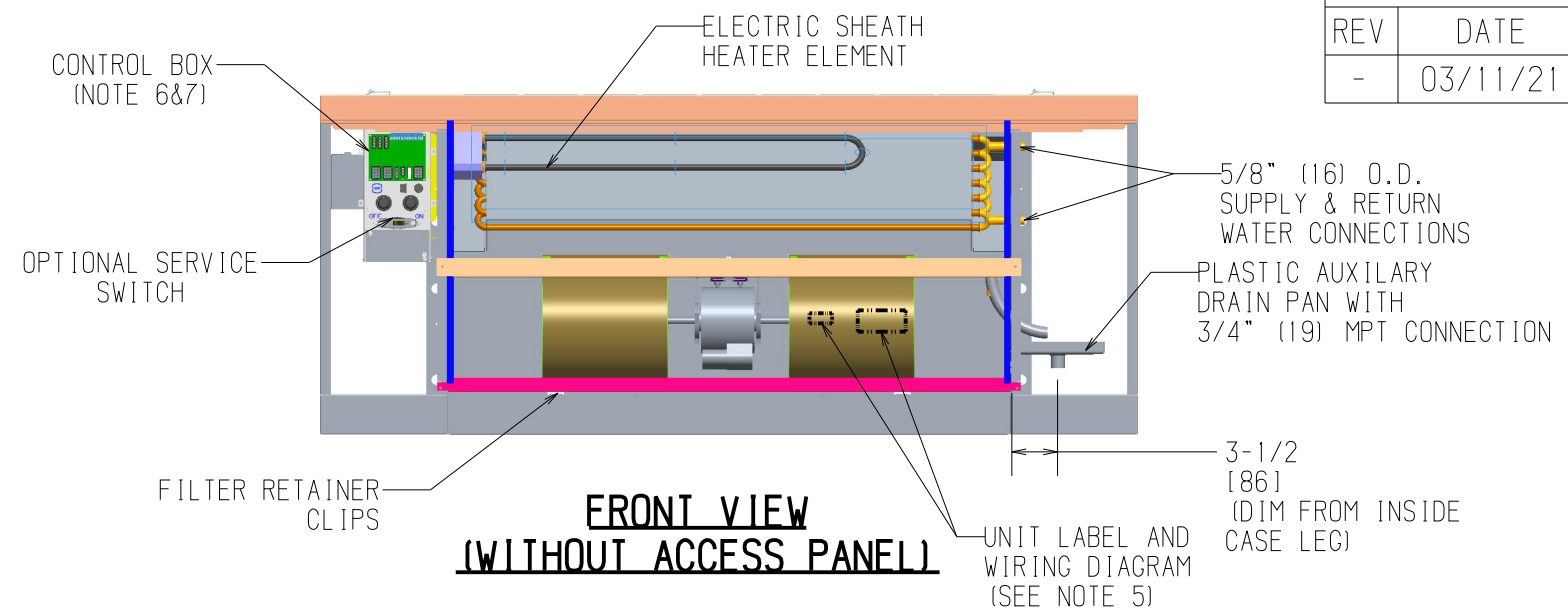

**FRONT VIEW
(WITHOUT ACCESS PANEL)**

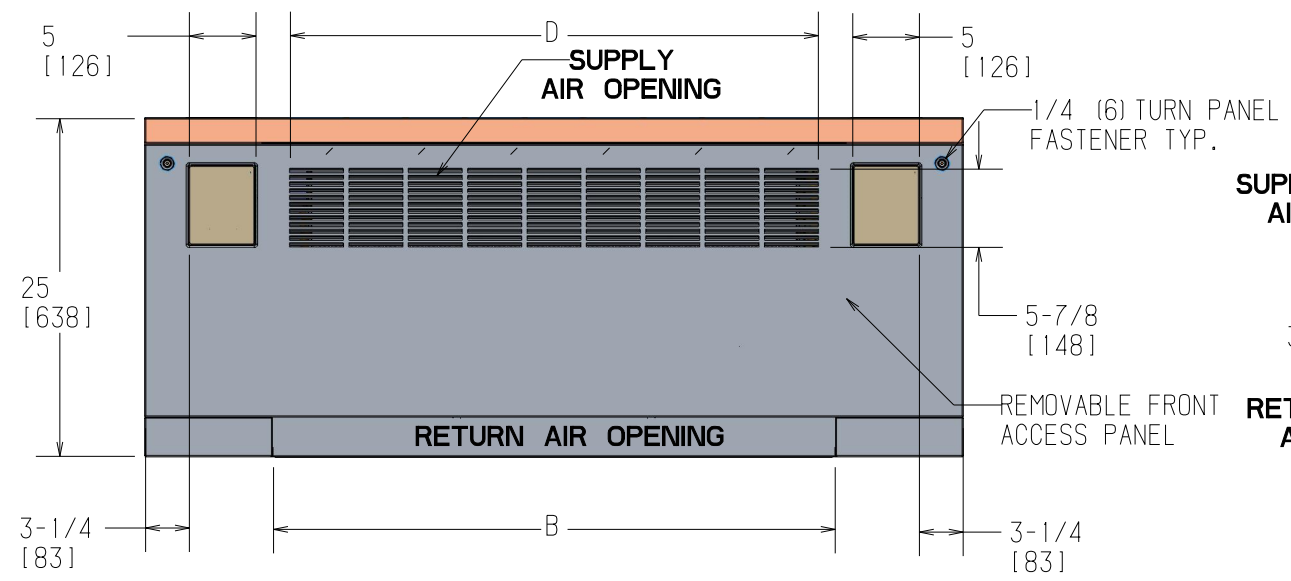

FRONT VIEW

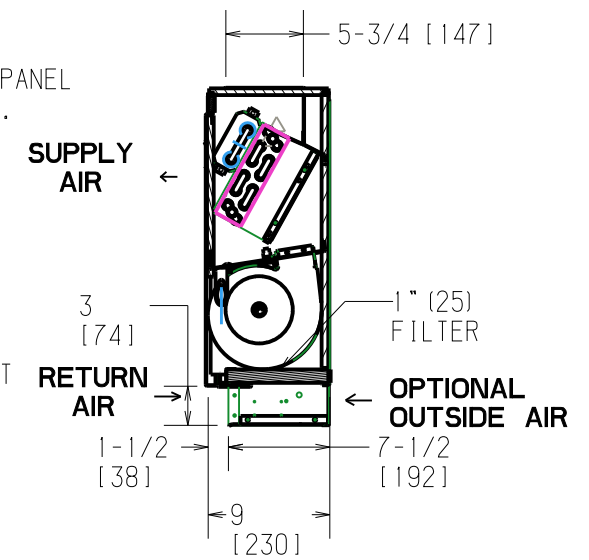

RIGHT SIDE VIEW

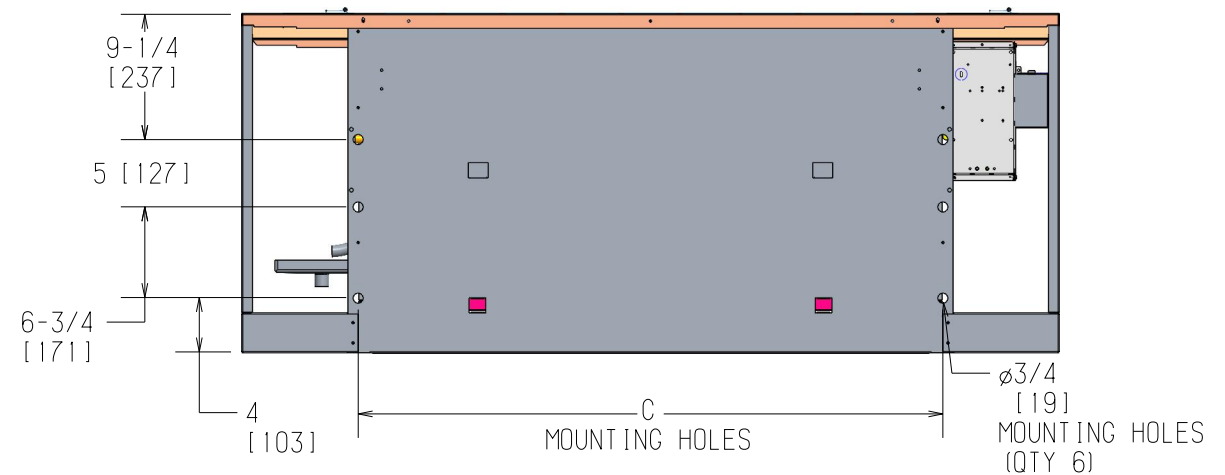

REAR MOUNTING VIEW

- NOTES:
 1. RH COIL SHOWN. LH OPPOSITE.
 2. ALL DIMENSIONS ARE +/- .25 (6). DRAWING NOT TO SCALE.
 3. PRODUCT SPECIFICATIONS ARE SUBJECT TO CHANGE WITHOUT NOTICE.
 4. CONTROL BOX SIZE AND POSITION MAY VARY (CONSULT FACTORY)
 5. POSITION MAY VARY.
 6. SERVICE ACCESS IS LOCATED ON THE FRONT OF THE CONTROL BOX.
 7. KNOCKOUTS ON THE BOTTOM AND SIDE OF THE CONTROL BOX FOR INCOMING POWER CONNECTIONS

Unit Model	Dimensions - Inches (Millimeters)				Quantity/Unit	
	A	B	C	D	Blower	Motor
FXY 02	41 (1041)	22 (559)	23-1/2 (597)	17-1/4 (438)	1	1
FXY 03	45 (1143)	26 (660)	27-1/2 (698)	21-1/2 (698)	1	1
FXY 04	51 (1295)	32 (813)	33-1/2 (851)	26 (660)	2	1
FXY 06	61 (1549)	42 (1067)	43-1/2 (1105)	39 (991)	2	1
FXY 08	63 (1600)	44 (1118)	45-1/2 (1156)	39 (991)	2	1
FXY 10	77 (1956)	58 (1473)	59-1/2 (1511)	52 (1321)	4	2
FXY 12	85 (2159)	66 (1676)	67-1/2 (1751)	61 (1549)	4	2



TITLE
 VERT CABINET FRNT SPLY
 ELECTRIC HEAT

DWG NO
1100-90044350

DRAWN J. FUSON	DATE 03/20/12	APPROVED J. GRAVES	REV -
DATE 03/20/12			DATE 03/20/12